

# BUTTERFLY VALVES - 250 PSI

\*NSF372 • Lug Design • Ductile Iron Body • Extended Neck  
 Bi-Directional • Molded Seat • ISO Mounting Pad • Locking Lever  
**SIZE 2" - 8"**

STANDARDS: MSS SP-67 & API-609 Cat. A

END CONNECTION: ANSI CL 125/150 FLANGES

WALL THICKNESS: KITZ STD

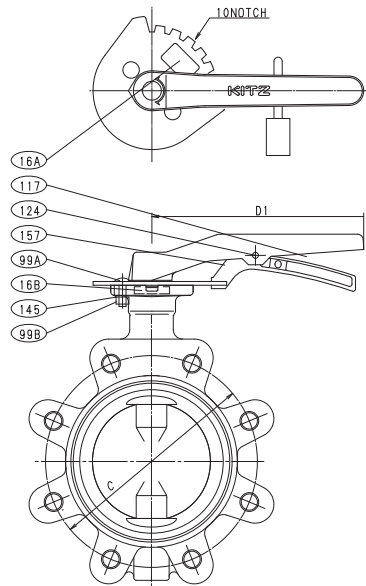
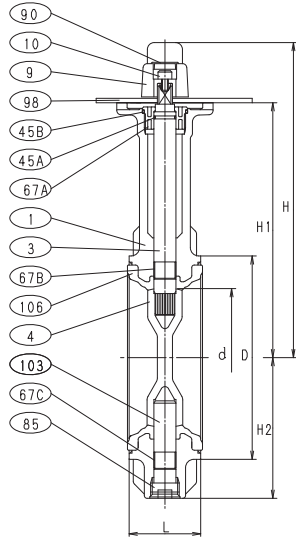

MATERIAL LIST		
NO.	NAME OF PART	SPECIFICATION
1	BODY	DUCTILE IRON (A536 Gr. 65-45-12)
3	STEM* (1)	STAINLESS STEEL (A276, Type 410; AISI, Type 329)
4	DISC	DUCTILE IRON, AL. BRONZE, AND 316 SS
9	LEVER (LOCKING)	ALUMINUM DIE-CAST
10	HANDLE	CARBON STEEL
16A/B	NAME PLATE	ALUMINUM
45A	O-RING	NBR/EPDM
45B	O-RING	NBR/EPDM
67A	BEARING	POLYACETAL
67B/C	STEM BEARING	G/F PTFE, METAL BACKED PTFE (6", 8")
85	PLUG	ZINC DIE-CAST (2)
90	CAP	P.V.C. (2"-6")
98	INDEX PLATE	CARBON STEEL
99A	SET BOLT	CARBON STEEL
99B	NUT	CARBON STEEL
103	BOTTOM STEM	STAINLESS STEEL (A276, TYPE 410; AISI, Type 329)
106	SEAT RUBBER (3)	NBR/EPDM
145	SPRING WASHER	CARBON STEEL
	STOP LEVER (8")	DUCTILE IRON (A536 Gr. 65-45-12)

- (1) Line scribed on top of the stem indicates the disc position
- (2) Chromate Coating
- (3) Vulcanized to the Body

DIMENSIONS											
SIZE	d	D	C	H	H1	H2	L	D1	Wafer Lug		
									Lbs	Lbs	
									Kgs	Kgs	
in. 2	1.97	3.54	4.75	7.52	5.79	2.64	1.69	7.09	4.2	6.6	
mm 50	50	90	120.5	191	147	67	43	180	1.9	3.0	
in. 2 1/2	2.56	4.09	5.50	7.83	6.10	2.95	1.81	7.09	5.1	7.9	
mm 65	65	104	139.5	199	155	75	46	180	2.3	3.6	
in. 3	3.15	4.88	6.00	8.54	6.81	3.58	1.81	7.09	6.8	11.0	
mm 80	80	124	152.5	217	173	91	46	180	3.1	5.1	
in. 4	3.94	5.75	7.50	8.94	7.20	3.98	2.06	7.09	7.7	18.0	
mm 100	100	146	190.5	227	183	101	52	180	3.5	8.1	
in. 5	4.92	6.93	8.50	10.43	8.31	5.00	2.19	9.06	13.0	25.0	
mm 125	125	176	216	265	211	127	56	230	5.8	11.0	
in. 6	5.91	8.11	9.50	10.91	8.78	5.47	2.19	9.06	18.0	30.0	
mm 150	150	206	241.5	277	223	139	56	230	8.0	14.0	
in. 8	7.76	10.12	11.75	11.61	9.76	6.65	2.38	13.78	28.0	48.0	
mm 200	197	257	298.5	295	248	169	60	350	13.0	22.0	



**Code # 6113 (B/E) L**  
 Disc: Ductile Iron (A536 + ENP)

**Code # 6123 (B/E) L**  
 Disc: Aluminum Bronze\* (C95400)

**Code # 6133 (B/E) L**  
 Disc: 316 SS\* (A351 Gr. CF8M)

**NOTE:**

KITZ lug style butterfly valves are rated for bi-directional dead end service to full working pressure of the valve with the downstream flange removed. In dead end service exceeding 96 hours, a downstream flange is recommended.



\*Butterfly valves with AlBrz or SS disc conform with lead content requirements for "lead free" plumbing as defined by California, Vermont, Maryland, and Louisiana state laws and the U.S. Safe Drinking Water Act. These products further conform with the requirements of NSF/ANSI Standard 372.